

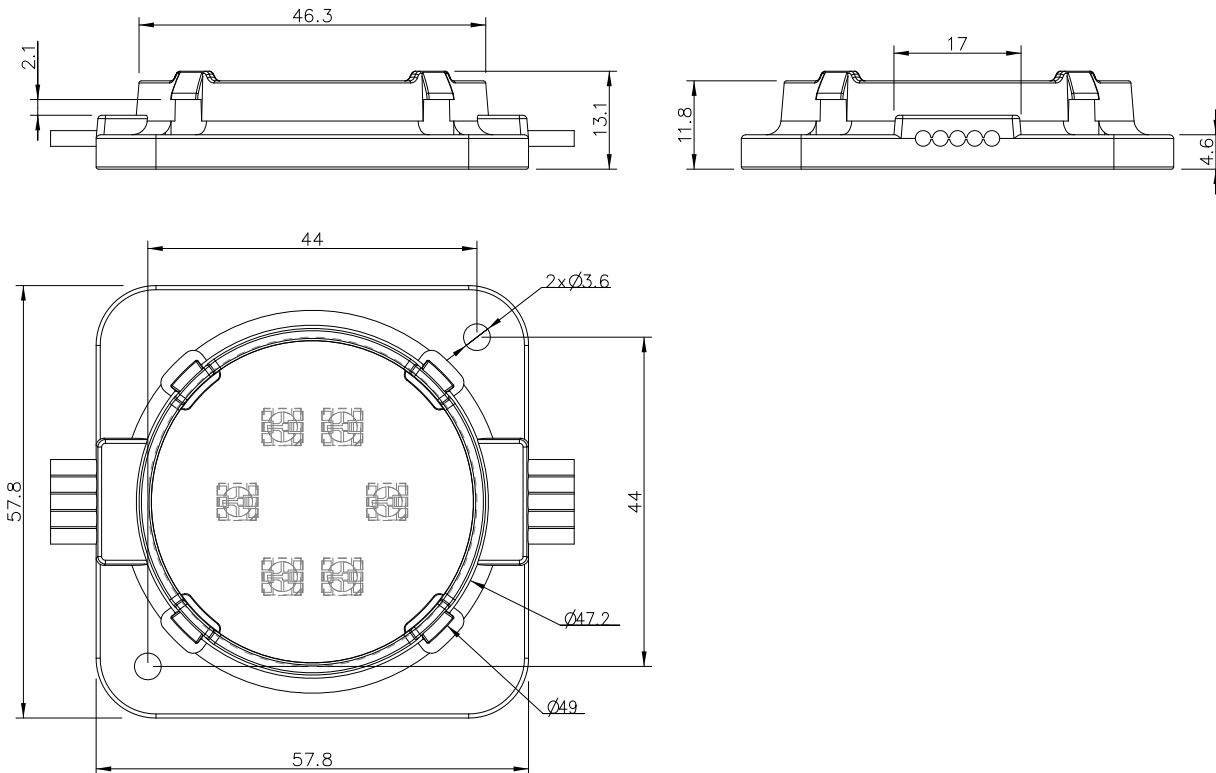

Weight / Peso	55 g. (1.94 oz) each Graph-i-Dot
Housing / Corpo proiettore	Transparent plastic
IK rating / classe IK	IK09
IP rating / grado IP	IP68 max -20 m.
Ambient temp./ Temperatura ambientale	-30°C to 50°C (-22°F to 122°F)
Power supply / Alimentazione	External PSU
Power / Potenza massima	1,44 W
Electrical class / Classe elettrica	III
Control / Sistema di controllo	USITT DMX-512
Channels / Canali	3
Color range / Colori	6 medium output full color LEDs (RGB, Dynamic White, Cold White or Warm White)
Optics/ Ottiche	na

Size



Important notices/Avvertimenti importanti

- This product must be installed in accordance with applicable national and local electrical and construction codes by a person familiar with the construction and operation of the product and the hazards involved. Failure to comply with the following installation instructions may result in death or serious injury.

Questo prodotto deve essere installato secondo le normative locali, da personale specializzato. La mancata osservanza delle istruzioni di installazione può portare a situazioni di pericolo all'incolumità della persona.

- Do not stare at the operating light source.

Non fissare la sorgente luminosa durante il suo funzionamento.

- The fixture might be damaged by excess voltage. The installation of an overvoltage protection device on the electrical system may reduce the risk of damage.

Apparecchiatura sensibile alle sovratensioni. L'installazione di un dispositivo di protezione delle sovratensioni sull'impianto elettrico attenua l'intensità di questi fenomeni proteggendo gli apparecchi dal rischio che vengano danneggiati.

- The use of an adequate magnetothermic switch along the power supply line is recommended.

E' consigliato l'uso di un adeguato interruttore magnetotermico/differenziale sulla linea di alimentazione.

- Connect the fixtures to each other only when disconnected from mains.

Collegare tra loro i proiettori solo quando nessuno di essi è collegato alla rete elettrica.

- Never leave cables and connectors unconnected or unprotected for long periods.

Non lasciare mai per lungo tempo agli agenti atmosferici cavi e connettori non collegati o non protetti.

- Disconnect power before installing or servicing to avoid electrical shock.

Togliere l'alimentazione prima di effettuare qualsiasi operazione all'interno dell'apparecchiatura.

- Disconnect power before any connection operation.

Togliere l'alimentazione prima di effettuare qualsiasi operazione di connessione tra gli apparecchi.

- Check voltage and frequency before powering the fixture. Do not exceed fixture specified voltage.

Prima di connettere l'apparecchio alla rete elettrica, verificate la compatibilità di tensione e frequenza.

- Do not handle the unit with wet hands or in wet environments.

Non maneggiate il prodotto con mani bagnate o in presenza di acqua.

- Apply to qualified staff for any maintenance service not described in this instructions manual.

Rivolgersi ad un tecnico qualificato per qualsiasi operazione di manutenzione ordinaria non descritta nel presente manuale.

- Do not exceed the maximum quantity of fixtures per line in order to avoid power surges.

Non superare il numero massimo specificato di apparecchi per linea per evitare pericoli di sovraccarichi di corrente.

- Before powering the unit, ensure to use cables and connectors with proper section and length, according to its power consumption.

Prima di effettuare le connessioni verificare la portata dei cavi / connettori e la lunghezza dei cavi tenendo conto dell'assorbimento del prodotto.

- Fix the projector by using screws, hooks or other adequate supports that can bear its weight.

Fissare il proiettore con viti, ganci o altri supporti in grado di sostenerne il peso.

- All devices connected to the DALI bus must be SELV type.

- Tutte le apparecchiature connesse al bus DALI devono essere di tipo SELV.



WARNING ! Fixing and connecting operations must mandatorily be carried out by qualified personnel only !

ATTENZIONE ! le operazioni di installazione e connessione devono obbligatoriamente essere eseguite solo da personale specializzato !

WARNING ! Ensure power supply is off before connecting or disconnecting fixtures !

ATTENZIONE ! Assicurarsi che l'alimentazione sia disattivata prima di collegare o scollegare i proiettori !

Connecting Graph-i-Dot.

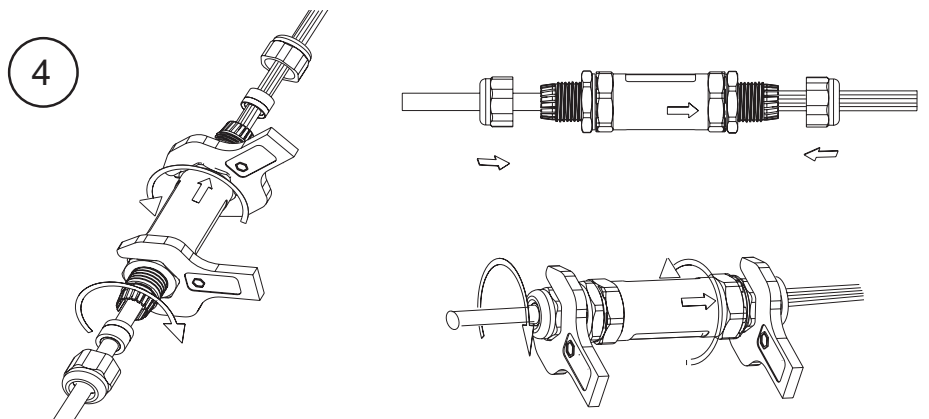
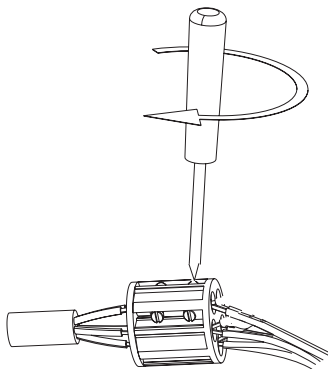
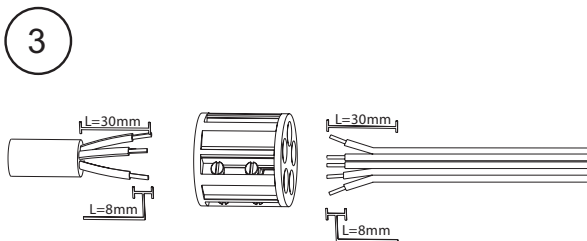
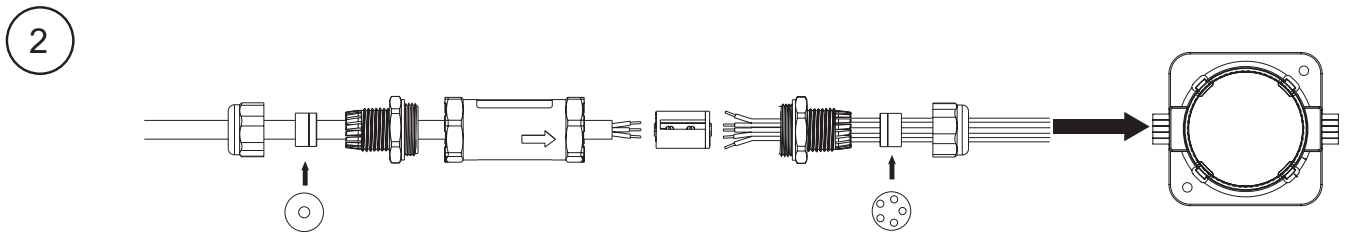
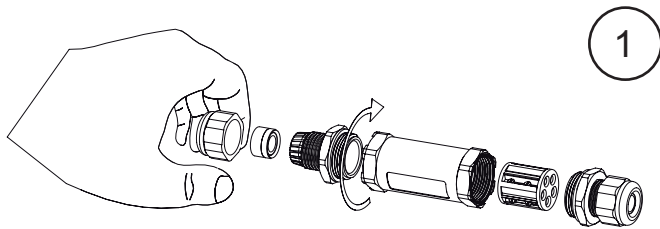

DMX start

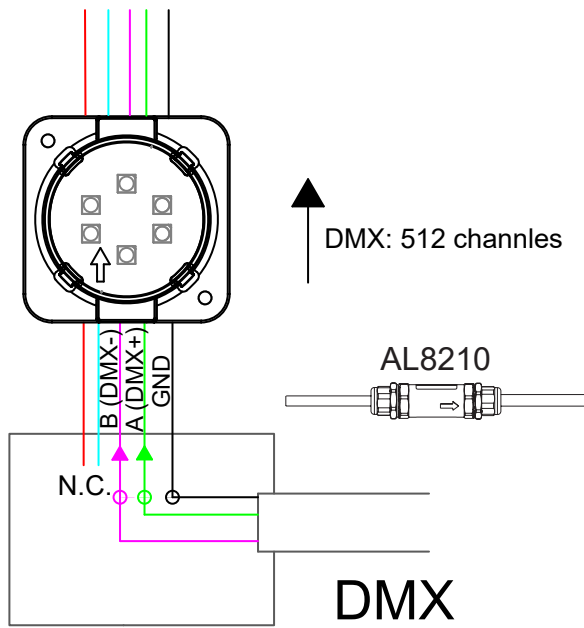

Standard configuration with DMX signal only.

24V + DMX from the control system

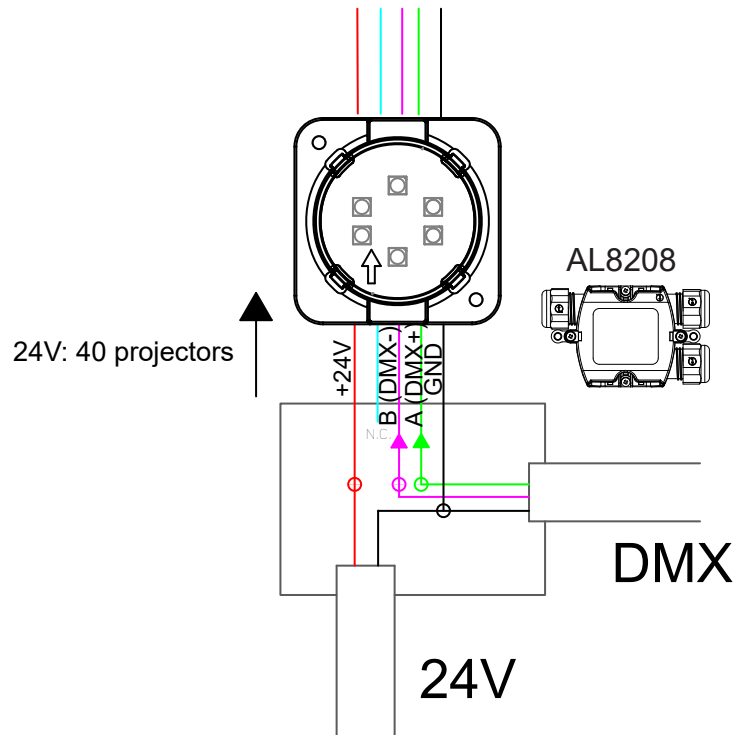

Configuration with both power supply and the DMX signal.

24V start

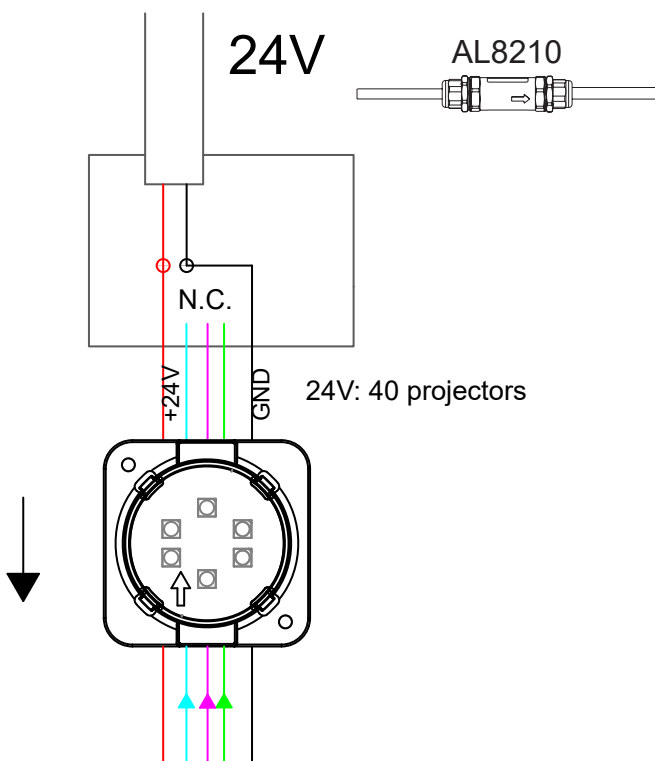

Alternative configuration with power supply only.

—	24 V +
—	ADR =GND
—	B (DMX -)
—	A (DMX +)
—	24 V GND
—	N.C. Not connected

Re-power and extension features.

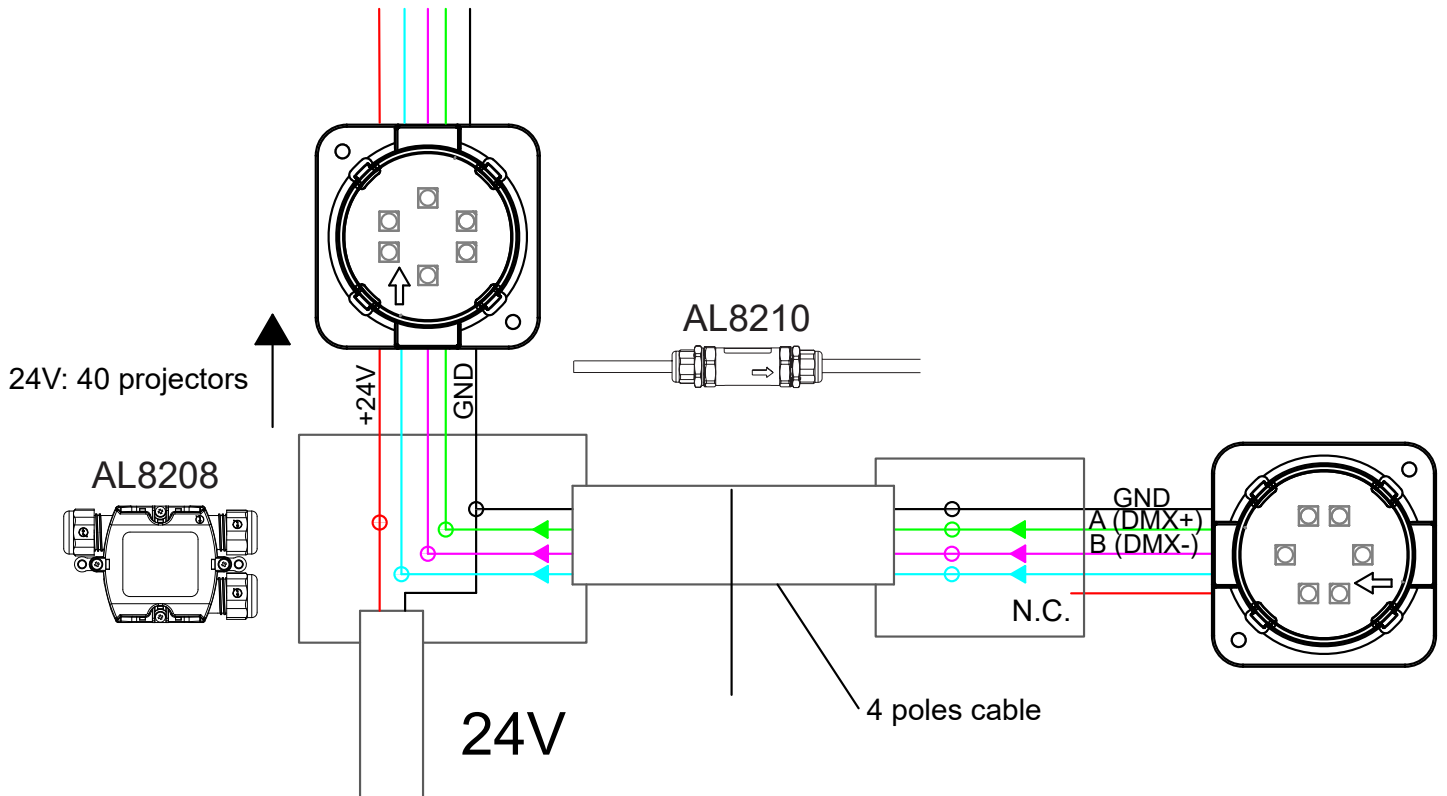

One in every 40 pixels must be repowered, while the DMX signal can be taken directly from the previous line, provided that the required number of DMX channels is available. The picture above also shows how to add an extension cable, if required.

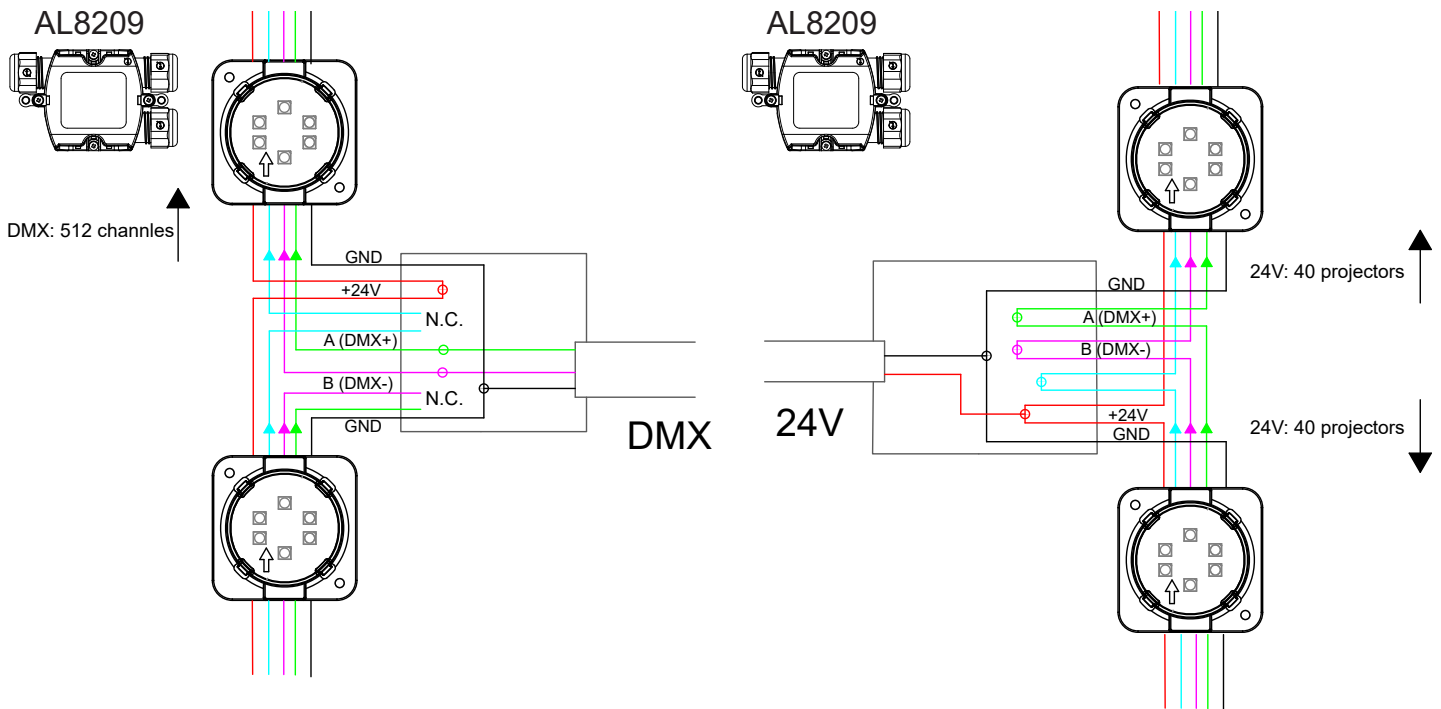

The picture above shows how to provide two lines of pixels with the DMX signal.

The picture above shows how to provide two lines of pixels with with +24V.

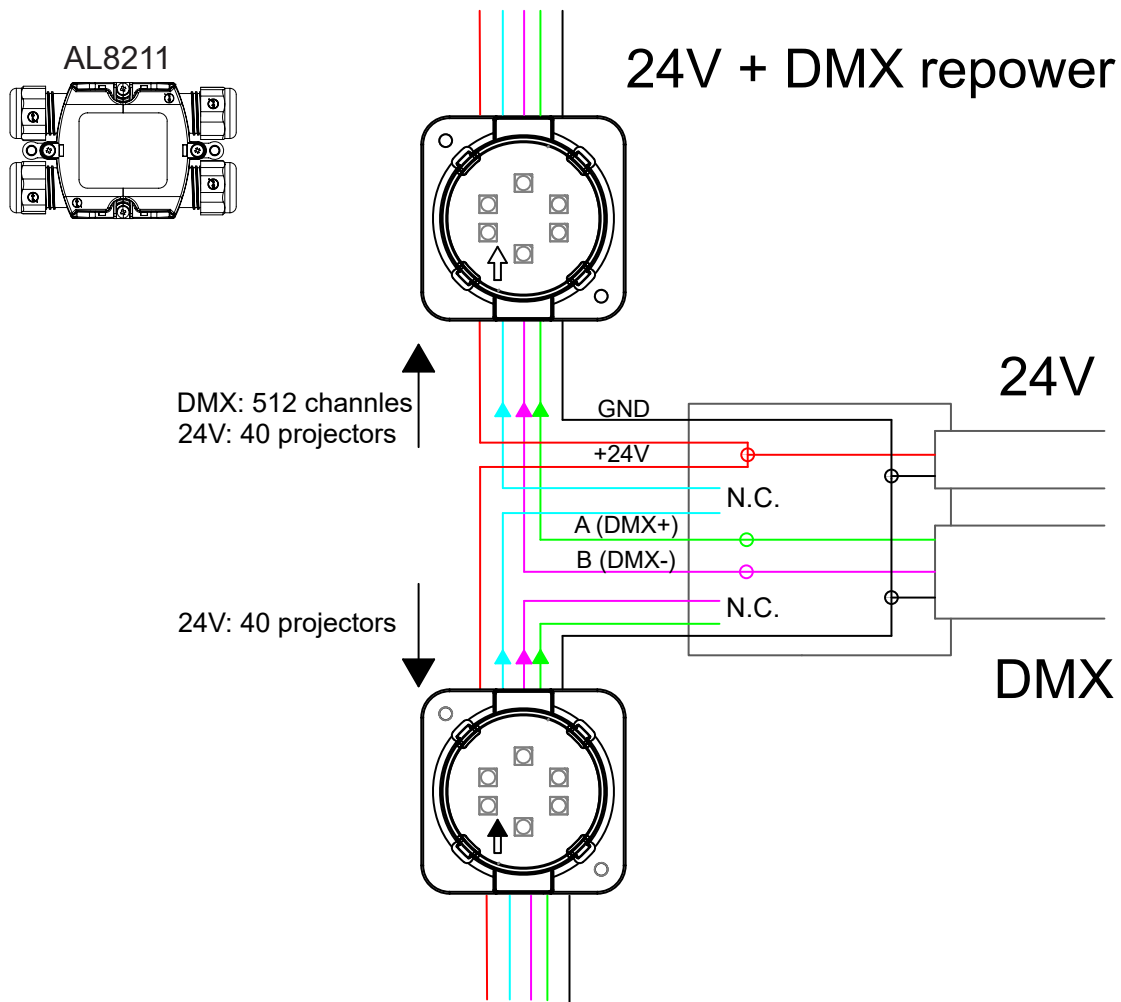

The picture above shows how to repower two lines of pixels with both DMX signal and +24V.

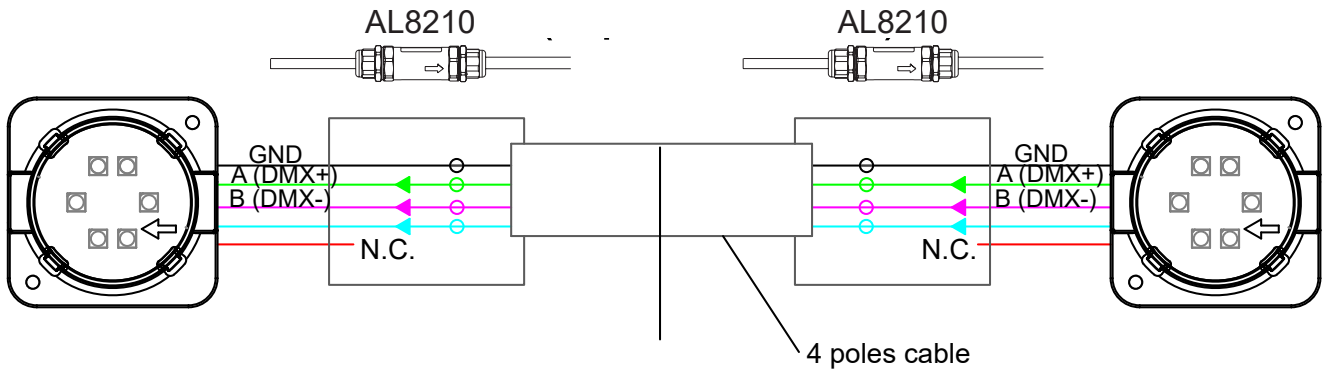

The picture above shows how to add a DMX only extension cable between two lines of pixels.

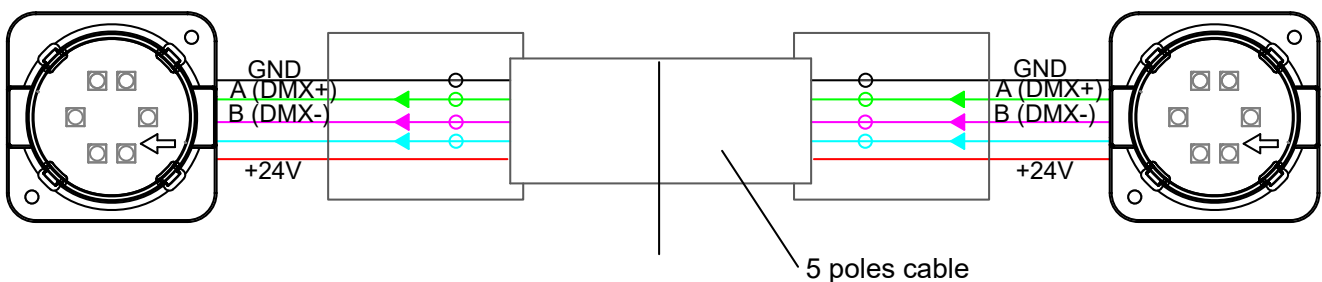

The picture above shows how to add an extension cable between two lines of pixels.

Terminal cap (AL4706)

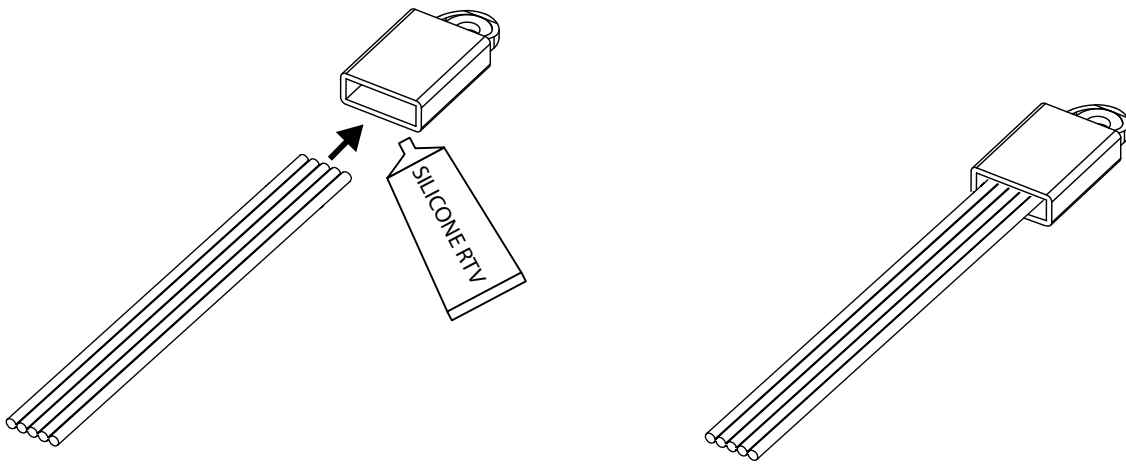

Fill the Terminator cap with silicone RTV and then put the flat cable in it. Let dry before fixing it onto a surface.

Replacing a faulty Graph-i-Dot.

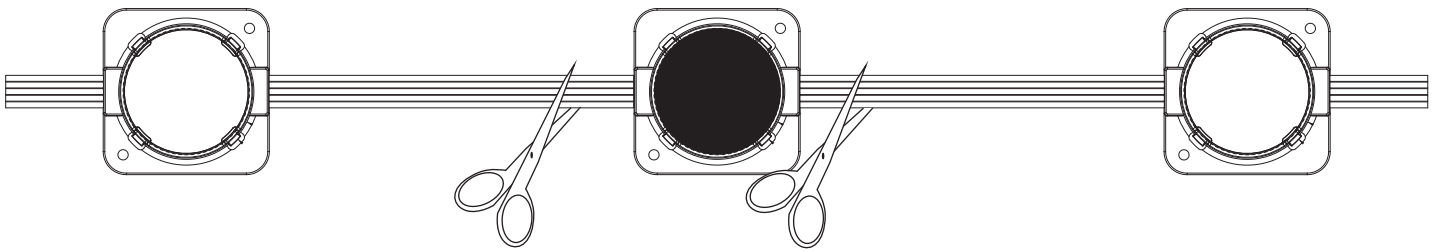

Remove the faulty Dot, cutting the flat cable as close as possible to the faulty unit.

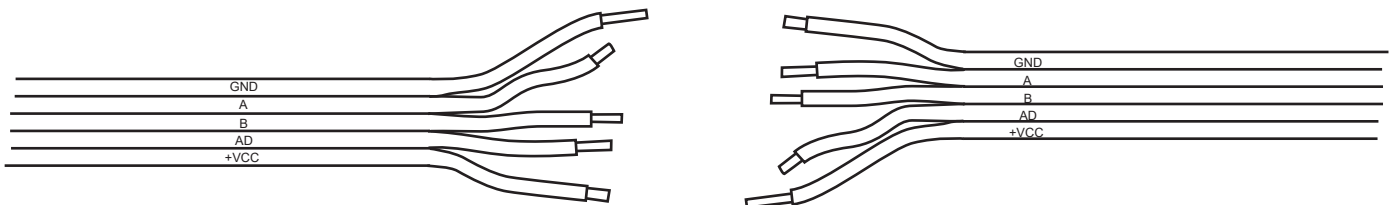

Split the ends of the cable as shown above. **WARNING!** In order to keep original distance between the single dots, we recommend to take careful measurements and, in case, adjust the cable length accordingly.

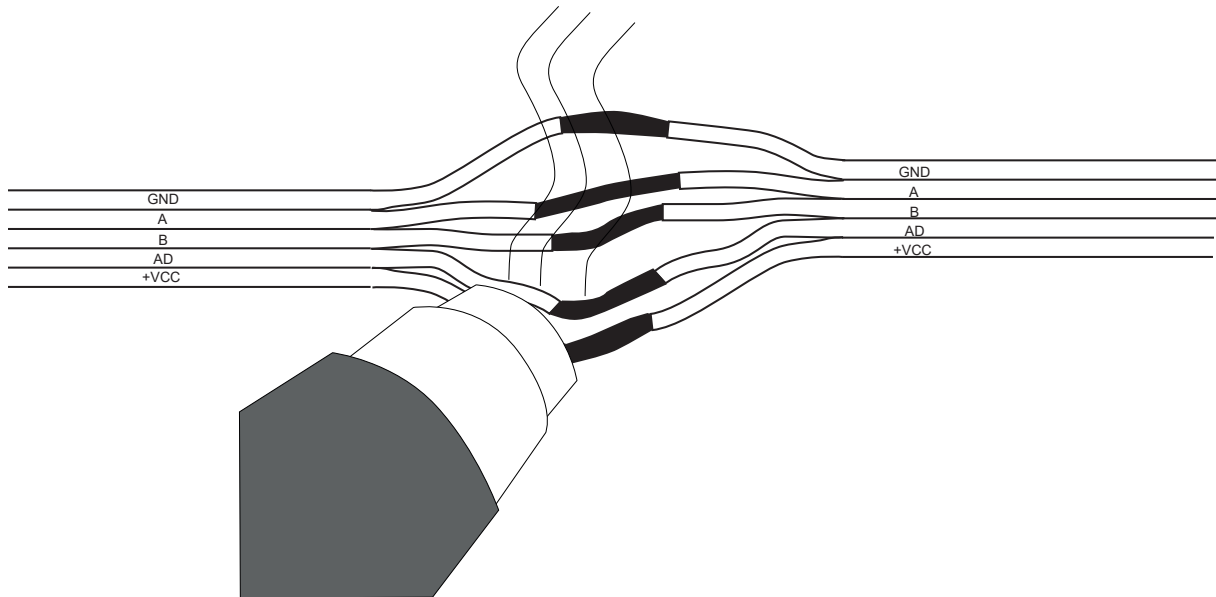

Wrap the split ends of the cable with single shrink sleeves before soldering them with the help of a thermoblower. PAY ATTENTION TO THE POLARITY WHILE CONNECTING THE ENDS!

Addressing the Graph-I-Dot chain.

An Address Setting DMX Driver (code AL4707, sold separately) is necessary to set the DMX address of each Dot of the chain.

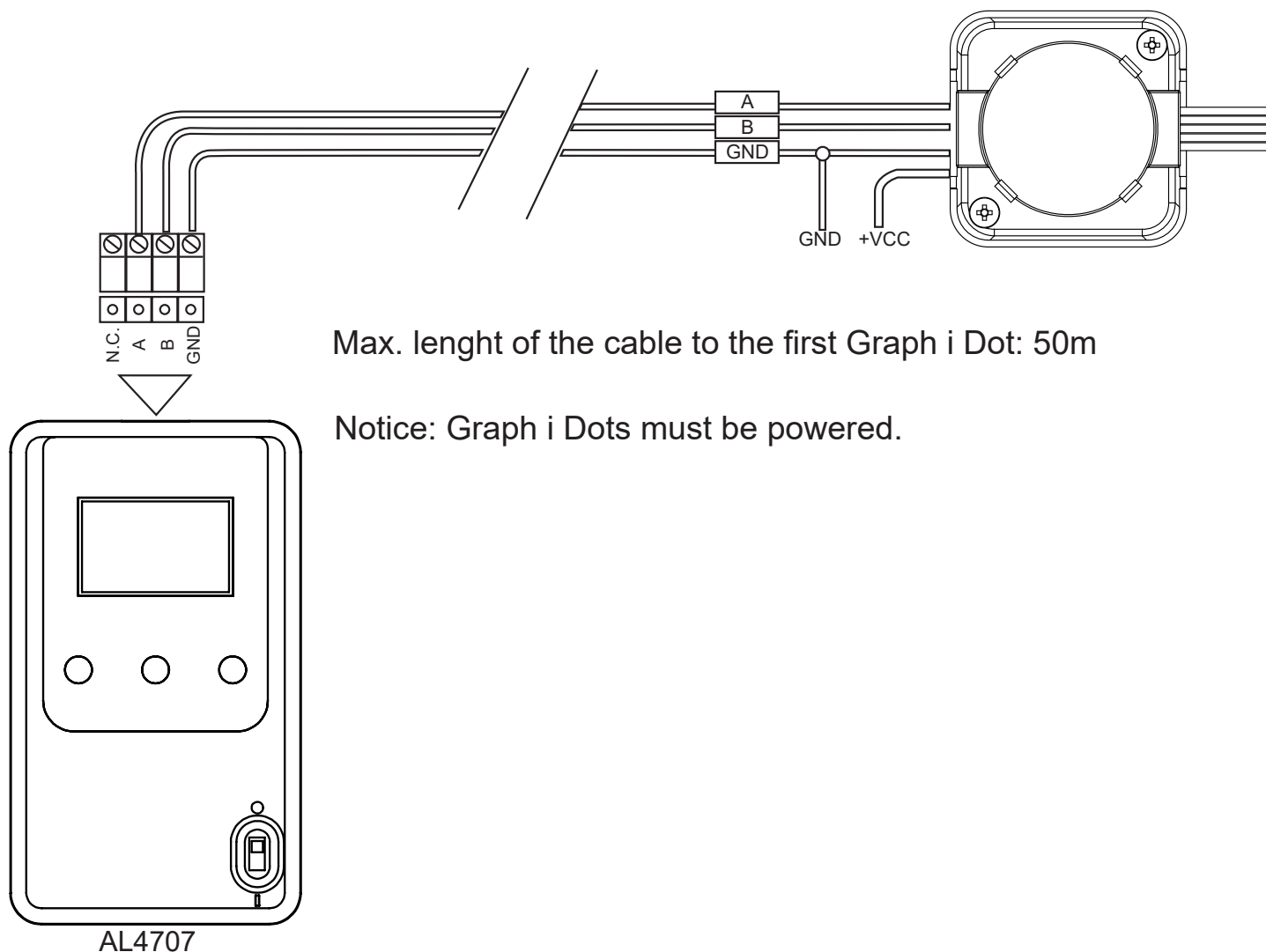

Max. length of the cable to the first Graph i Dot: 50m

Notice: Graph i Dots must be powered.

Connect the beginning of the chain to the Address Setting DMX Driver AL4707 as shown in the picture above.

AL4707 Address Setting DMX Driver menu.

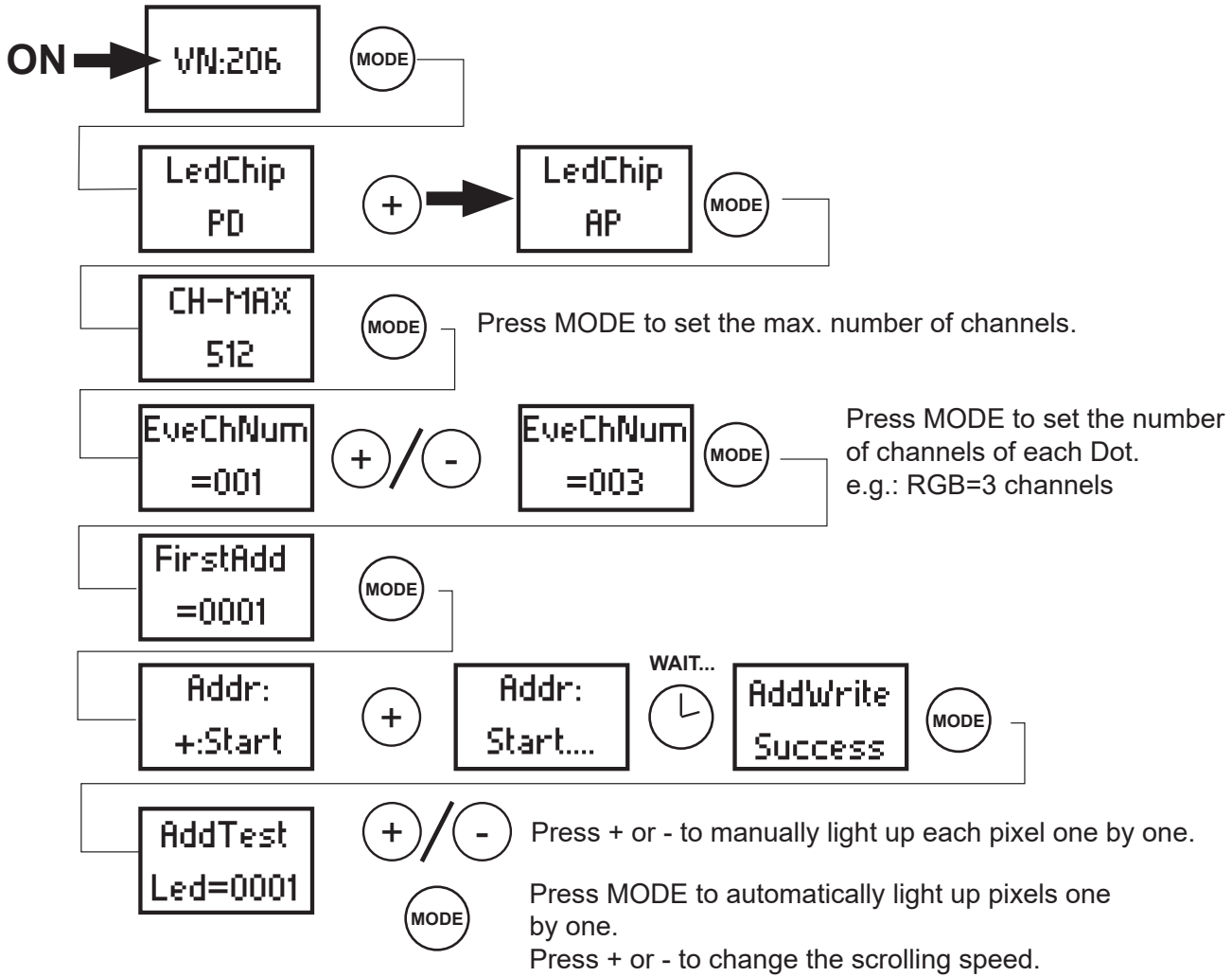

If the test has confirmed that the operation is correct, press MODE in order to end the procedure.

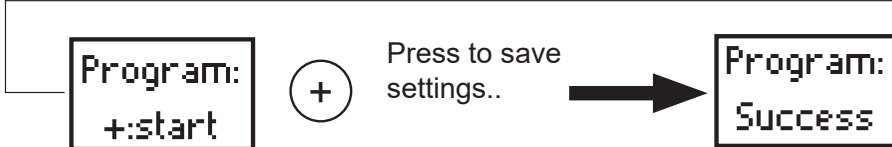
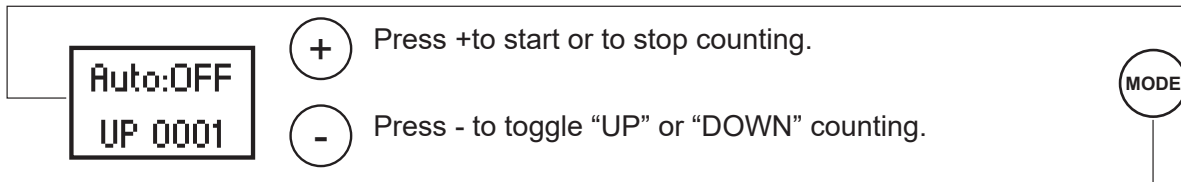
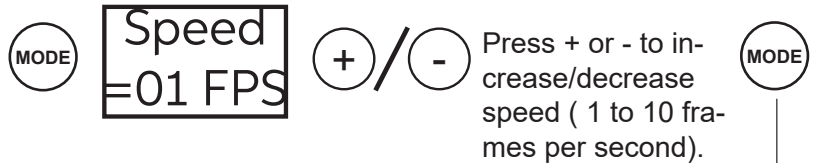

Installation directions

Installation on a surface

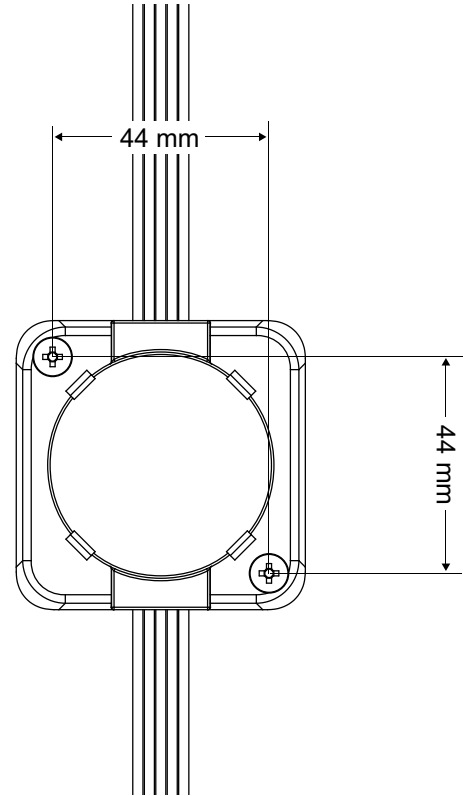
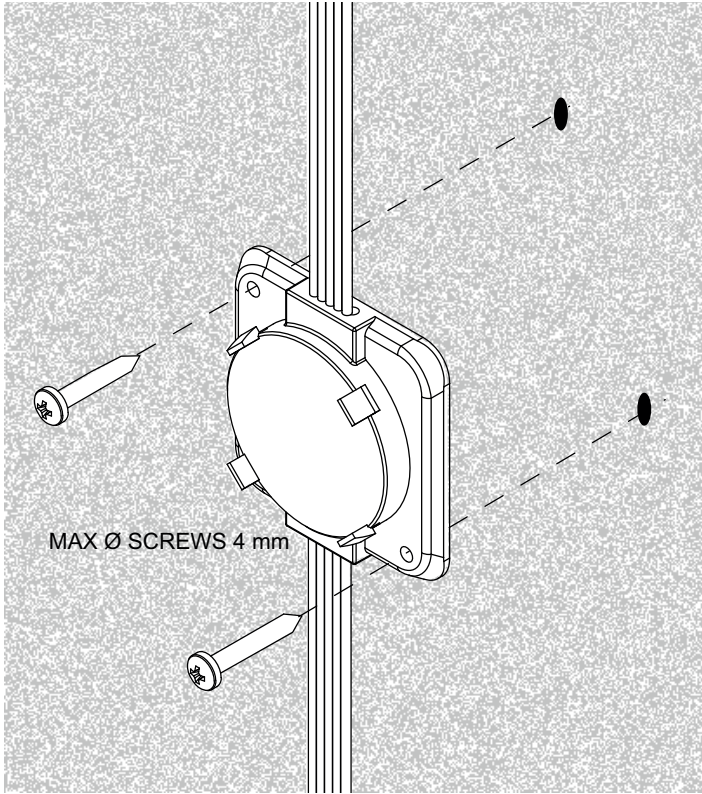

Installation on a surface by using the optional Fixing plate (AL4708)

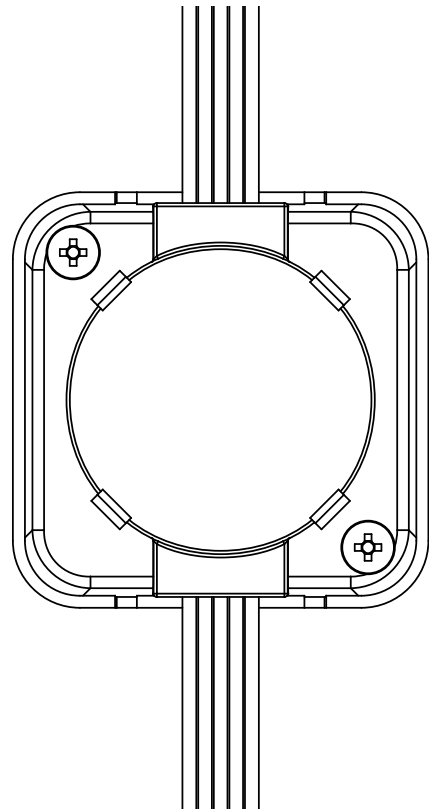
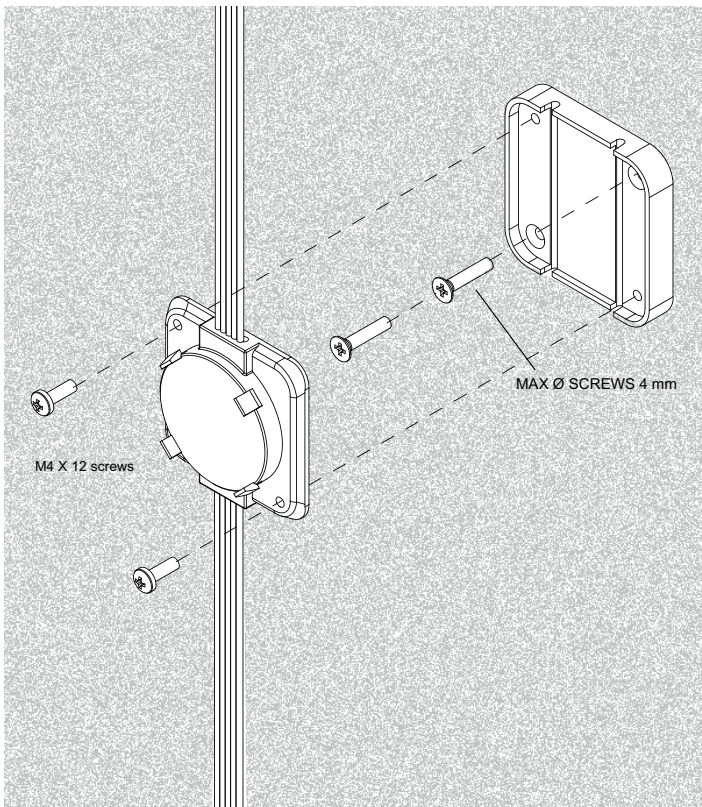

Installation on a steel rope by using the optional Fixing Plate (AL4708)

